

# T-975-AB INSTALLATION INSTRUCTIONS

## 1913-25

### Model T Pickup Bed Instructions

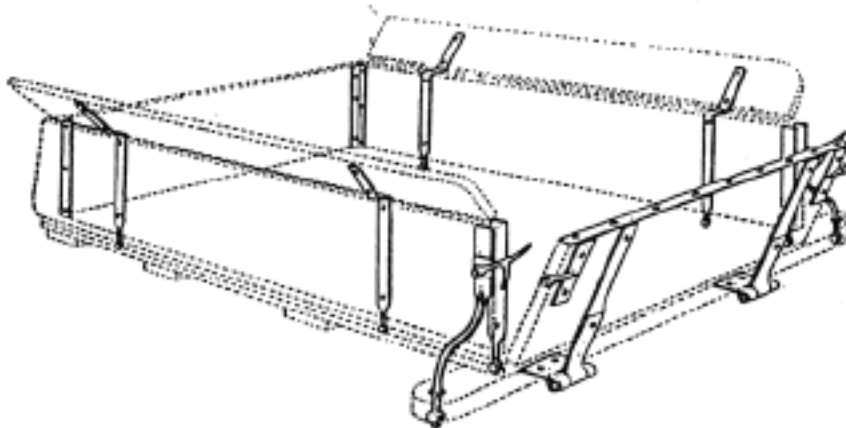

This handsome pickup bed is a copy of the popular accessory bed manufactured by the Cleveland Hardware Co. in Cleveland, Ohio. All wood is manufactured from oak or ash hardwood to the original specifications. All brackets are powder coated black for long life and durability. All hardware is included and labeled for location. We recommend you completely assemble bed and fit to chassis before finishing the wood.

1. Lay sills out according to dimensions on the following page and lay floor boards on top of them. Originally, these floor boards were nailed to sills. We provide wood screws with the kit to fasten the floor boards to the sills. We recommend screwing the floor boards down last. You will have to predrill for these wood screws.
2. Insert side braces and flare board irons in holes in bottom boards and bolt on side panels, bolting inside strap at rear end of side panel.
3. Now bolt on the front panel using angle irons furnished, after which bolt on hinges and tail gate.
4. The bolt which fastens the male end gate latch passes through both outside brace, side panel, and inside strap. Flat washers are provided here for shimming.
5. The drawing on the following page labeled 'COMPLETED FLOOR OF BODY AFTER BEING ASSEMBLED' shows the location for drilling the holes for mounting the bed to your body. BEFORE you drill these holes, we recommend that you position the bed on your T and mark where your original holes are for mounting. You can then remove the bed and double check these dimensions. 3" 3/8 carriage bolts are provided for mounting the bed to the frame. This will require that you drill the holes larger on the frame using a 13/32" drill bit. If you do not want to drill your frame, you can get 1/4" carriage bolts from your local hardware store in place of the 3/8" that come in your kit.
6. Cut front sill for battery access and attach to battery cover board per instructions on the following page showing completed floor.

COMPLETED FLOOR OF BODY AFTER BEING ASSEMBLED

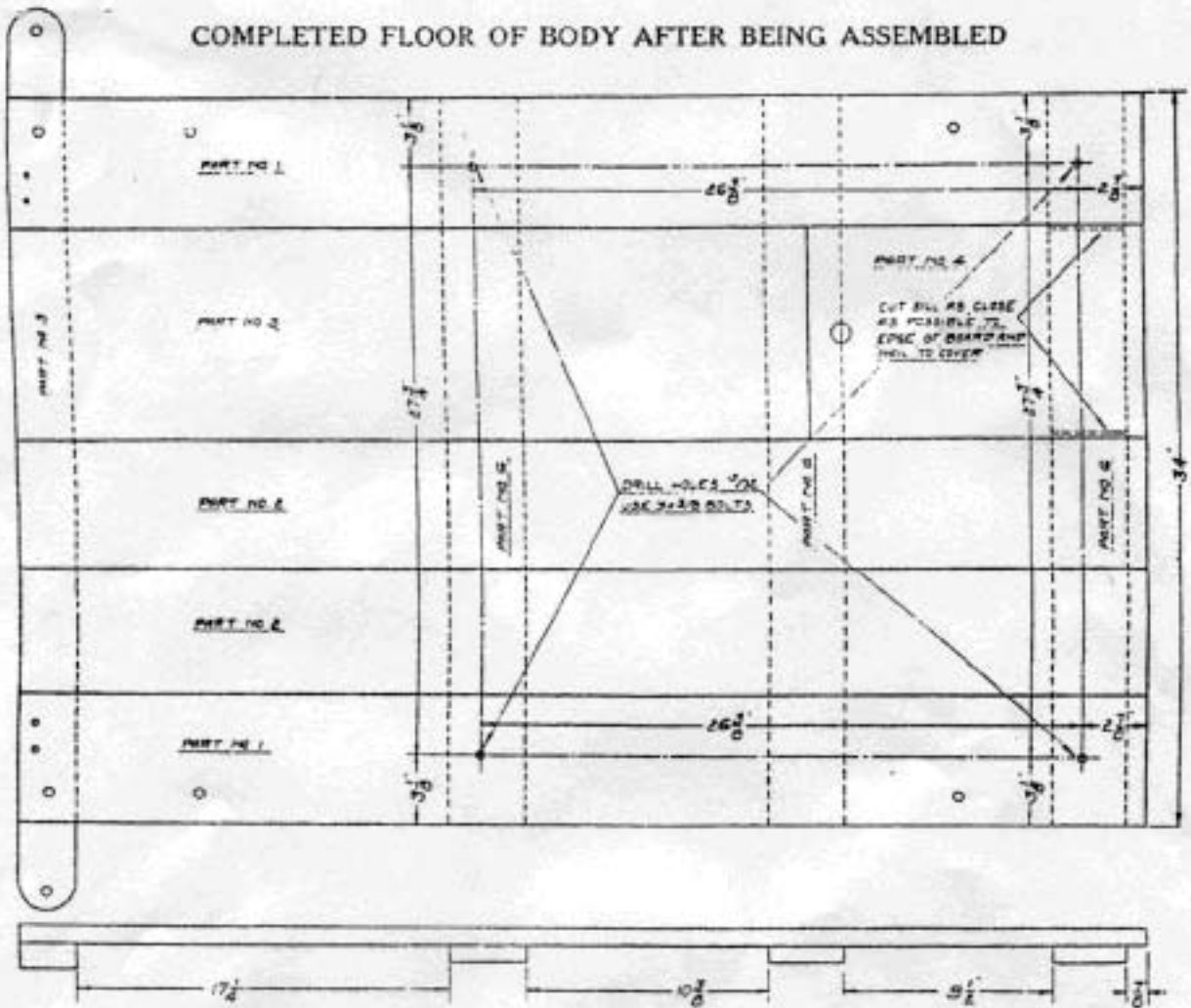

DRAWINGS 1-2-3-4—DETAIL OF FLOOR BOARDS

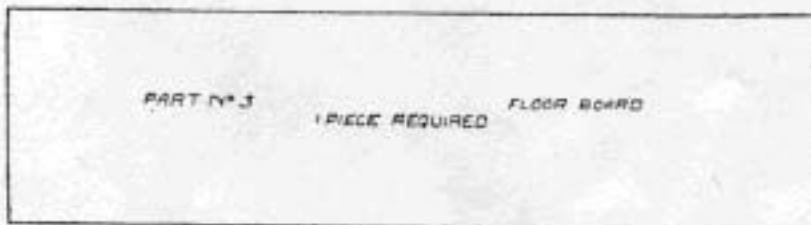
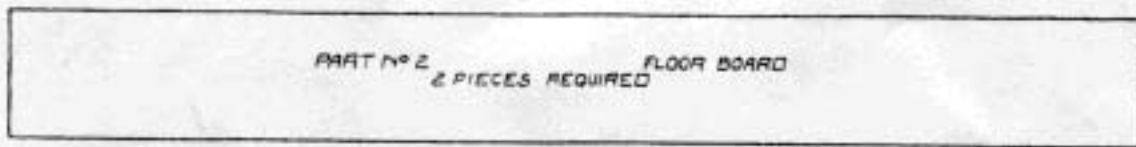
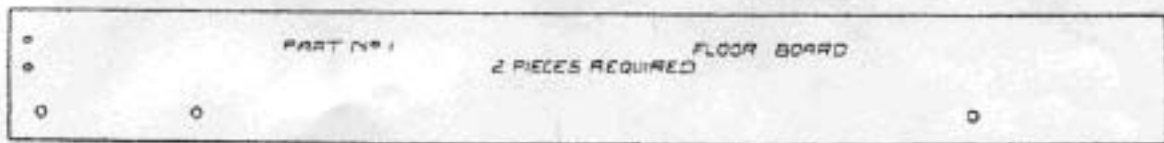

PART NO. 4  
1 PIECE REQUIRED

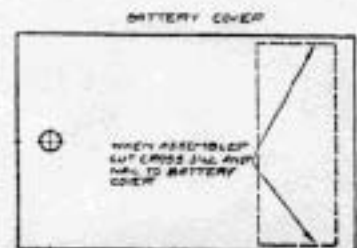

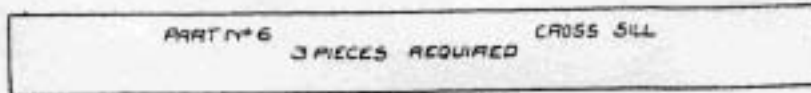
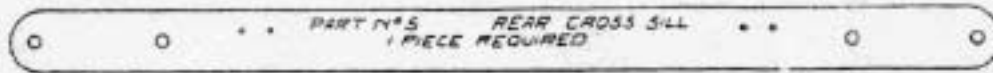

DRAWINGS 7, 8, and 9—DETAIL OF SIDES AND ENDS

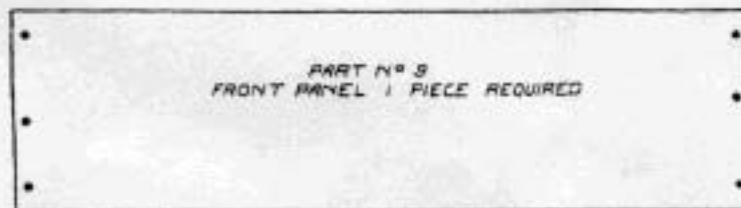
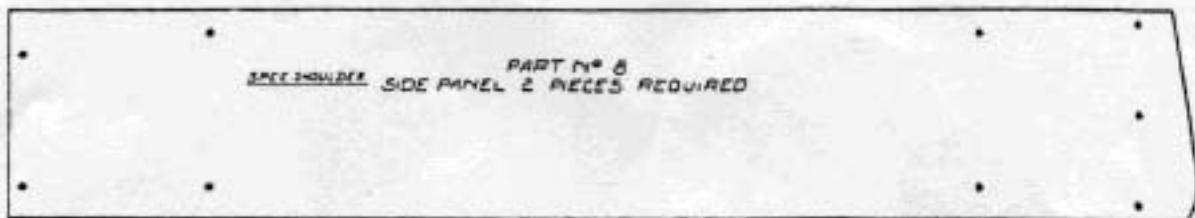
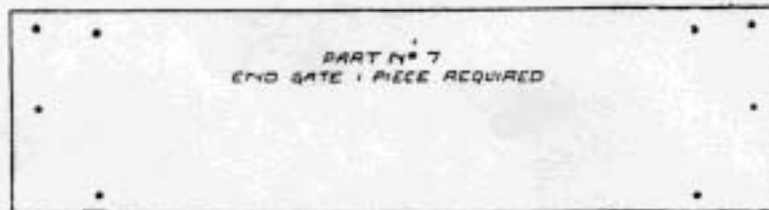

DRAWING 10—DETAIL OF FLARE BOARDS

