

T-3082-VW OIL PUMP ADAPTER, V.W.

The adapter Adapts the VW oil pump to the rear of the camshaft, the adapter attaches to two of the holes that previously held the mag field coil.

A as cast adapter is furnished and must be machined.

Suggested machining operations

- Bore the open hole to snug slip fit on the Model T rear camshaft bushing mill mounting surface.
- Mill oil pump side and drill, spot 2 mounting holes.
- Dismantle VW pump. Mount on face plate in lathe and indicate bore to within .001" T.I.R. (Total Indicator Runout) turn shout to just clean up.
- Make suitable bushing for above turning, see sketch.

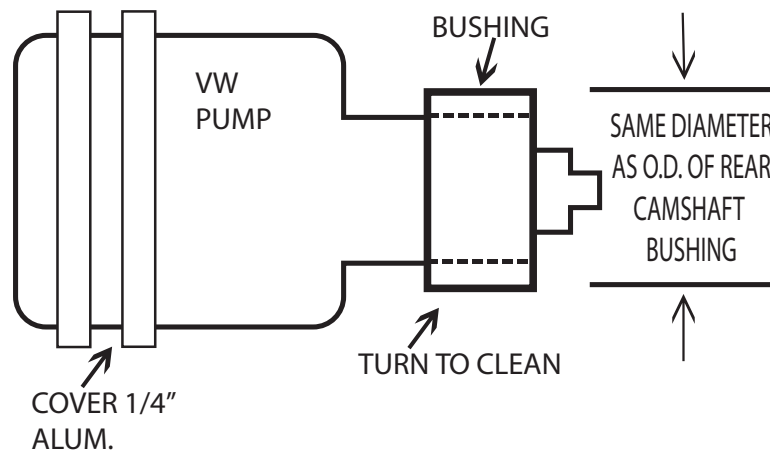

- Construct cover from 1/4" aluminum.
- Cut slot in end of camshaft alter length if necessary.
- Drill and tap 3 mounting holes 1/4 - 20 unc., Note fourth hole will be over 3/8" bolt opening.
- Torque two 3/8" bolts. Mark radial location of bolt under pump. Mount pump
- Transfer and tap head of bolt of 3/8" bolt 1/4 - 20 unc

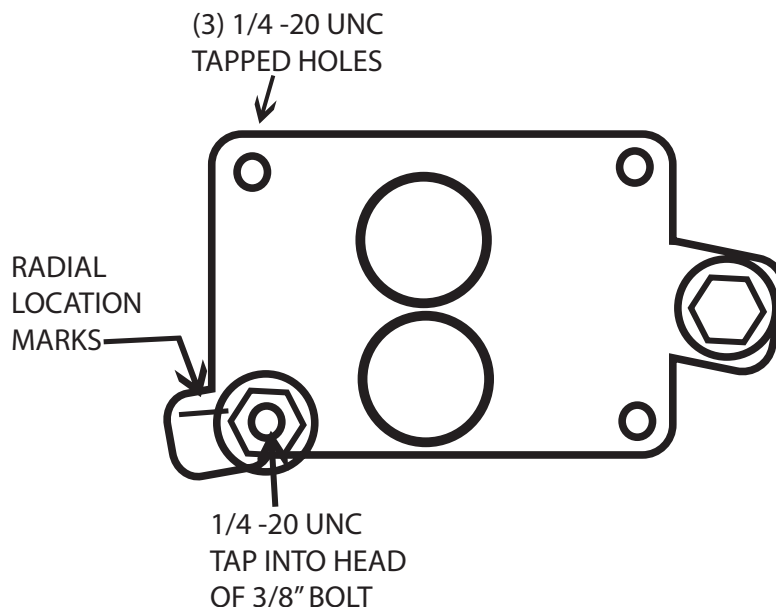

You are own your own as to how you want to do the piping.