

A-6381 FLYWHEEL GAUGE INSTRUCTIONS

FLYWHEEL HOUSING VARIATION MEASUREMENT

This measurement checks the alignment of the crankshaft end flange and the flywheel with the rear face of the flywheel housing. Misalignment of the flywheel housing creates a misalignment of the clutch housing (bell housing), which in turn causes a misalignment of the transmission drive gear with respect to the flywheel, clutch plate, and clutch pressure plate. This measurement can be made with a dial gauge or a crankshaft-to-housing gauge and a flywheel-to-housing-gauge. The crankshaft end flange must be square with the flywheel housing rear face to within .006" maximum variation.

1. Thoroughly clean mating surfaces of the flywheel housing and block. Place a paper gasket between the flywheel housing and the block. Securely bolt the housing to the block with four (4) attaching bolts (7/16-14 X 1-1/16" drilled hex head). Torque the bolts to 55 ft. lbs. Do not safety wire at this time.
2. Bolt the crank-to-flywheel housing gauge to the crankshaft flange using two of the flywheel attaching bolts (7/16-20 X 13/16 drilled head). Add spacers if necessary to allow the gauge to be absolutely tight against the crankshaft flange.

CAUTION

Do not allow the attaching bolts to extend more than 1/16" beyond the front side of the flange, causing possible damage to the rear main oil slinger.

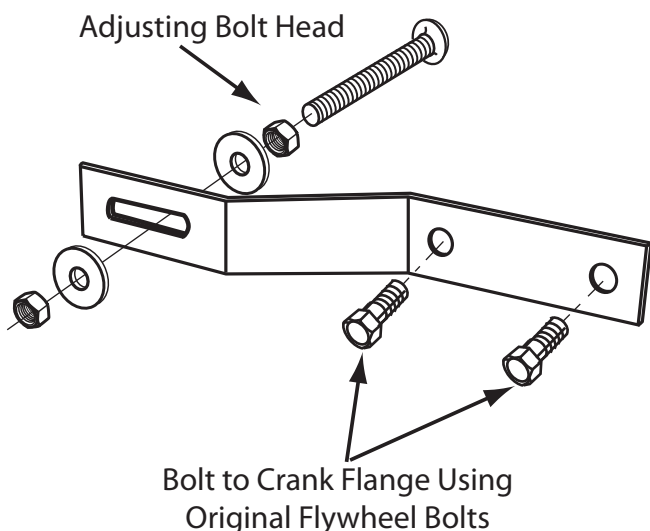

Crank-To-Flywheel Housing Gauge

3. Attach the throttle control bracket to the top of the flywheel housing at the two ears (7/16-14 X 1-3/4" hex head bolts and lock washers). before tightening the two bolts, insert a horseshoe shaped shim (about .0010" thick) under each ear, over the bolt shaft, and then securely tighten.
4. Set the adjusting bolt head on the gauge for .030" clearance from the flywheel housing rear face.
5. At about every 30°, check the clearance between the gauge adjusting bolt and the housing rear face. A maximum variation of .006" is allowable. Excess variation can usually be adjusted out by varying the thickness of the horseshoe shims under the two ears for the throttle bracket. The flywheel housing should be replaced if the variation is greater than .006" around the housing rear face, usually caused by a warped housing.
6. After completing the crank-to-flywheel housing check, remove the gauge and safety wire the flywheel housing bolt heads.
7. Screw two short manifold studs into two adjacent holes in the crankshaft flange to use as guides when putting the flywheel in place on the crankshaft flange.

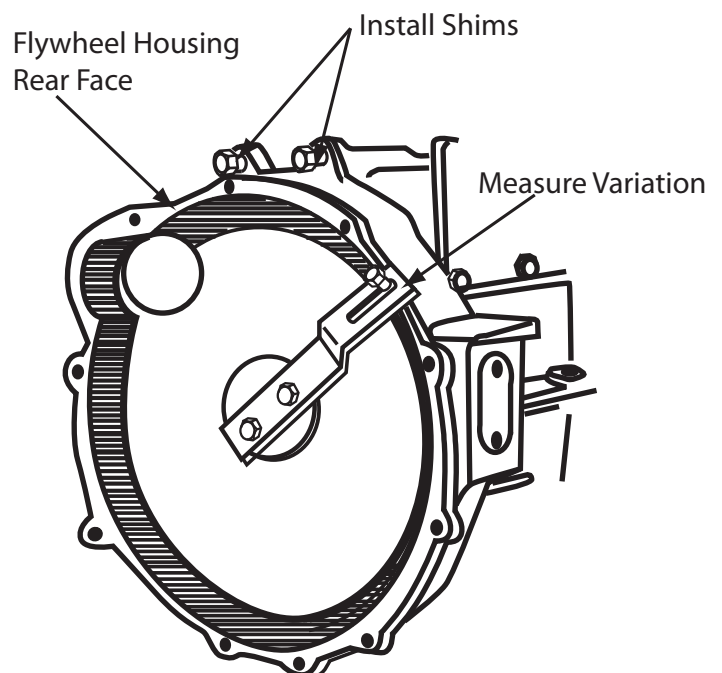

Crank-To-Flywheel Housing Variation Check

NOTE

The flywheel pilot bearing should be replaced before installing the flywheel.

8. Set the flywheel in place on the crankshaft flange. With the flywheel firmly seated over the dowels and against the crank flange, remove the two manifold studs and place the dowel retaining plate in the center of the flywheel. Insert four (4) mounting bolts (7/16-20 X 13/16" with drilled hex head) and torque to 55 ft. lbs. Safety wire the bolt heads.

CAUTION

Do not allow the flywheel mounting bolts to extend more than 1/16" beyond the front side of the flange, causing possible damage to the rear of the oil slinger.

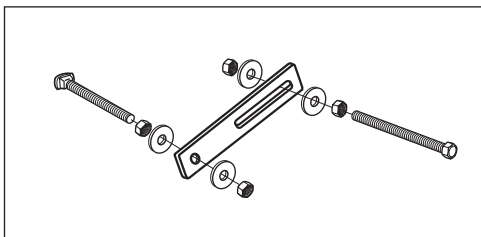
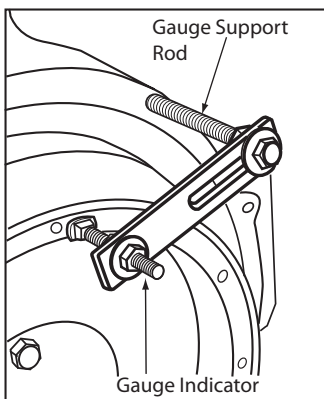
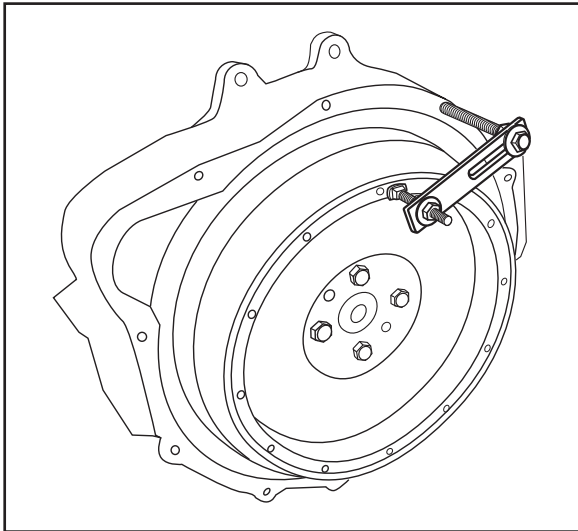

FLYWHEEL WOBBLE TEST

1. Install the Flywheel Wobble Gauge by screwing the long threaded support rod into any one of the flywheel housing bolt holes. Lock in place with the attached locking nut.
2. Position the top bar over the top edge of the flywheel and lock in place with the locking nuts.
3. While rotating the flywheel, set the adjusting carriage bolt head (Gauge Indicator) so that it is about .20" above the edge of the flywheel. Lock the adjusting bolt in place with the top and bottom locking nuts.
4. Slowly rotate the flywheel 360 degrees. Using a feeler gauge, measure the gap between the indicator bolt head and the flywheel top surface. If more than .005" variation is detected, there is too much flywheel wobble and will cause engine vibrations. Because of dirt and foreign matter, the flywheel may not be seated squarely on the crank flange. Reset the flywheel on the crank flange and retest. Check for warped flywheel.

NOTE

A dial Indicator may be used in place of the carriage bolt indicator. Attach the Dial Indicator support rod (supplied) on the gauge plate in place of the carriage bolt indicator. Attach a Dial Indicator to the support rod.

5. If the variation is more than .005", there will be too much wobble and the flywheel should be remachined or replaced.
6. After completing the flywheel wobble variation check, remove the flywheel wobble gauge and install the clutch and pressure plate, using twelve (12) bolts and lock washers (5/16-18 X 3/4" hex head). Torque to 20 ft. lbs.

NOTE: A dial indicator can be used for the wobble test with more accuracy than the wobble gauge.

From the Les Andrews book, **Model A Ford Mechanics Handbook Vol. 1**