

A-6010-P HEAD PULLER INSTRUCTIONS

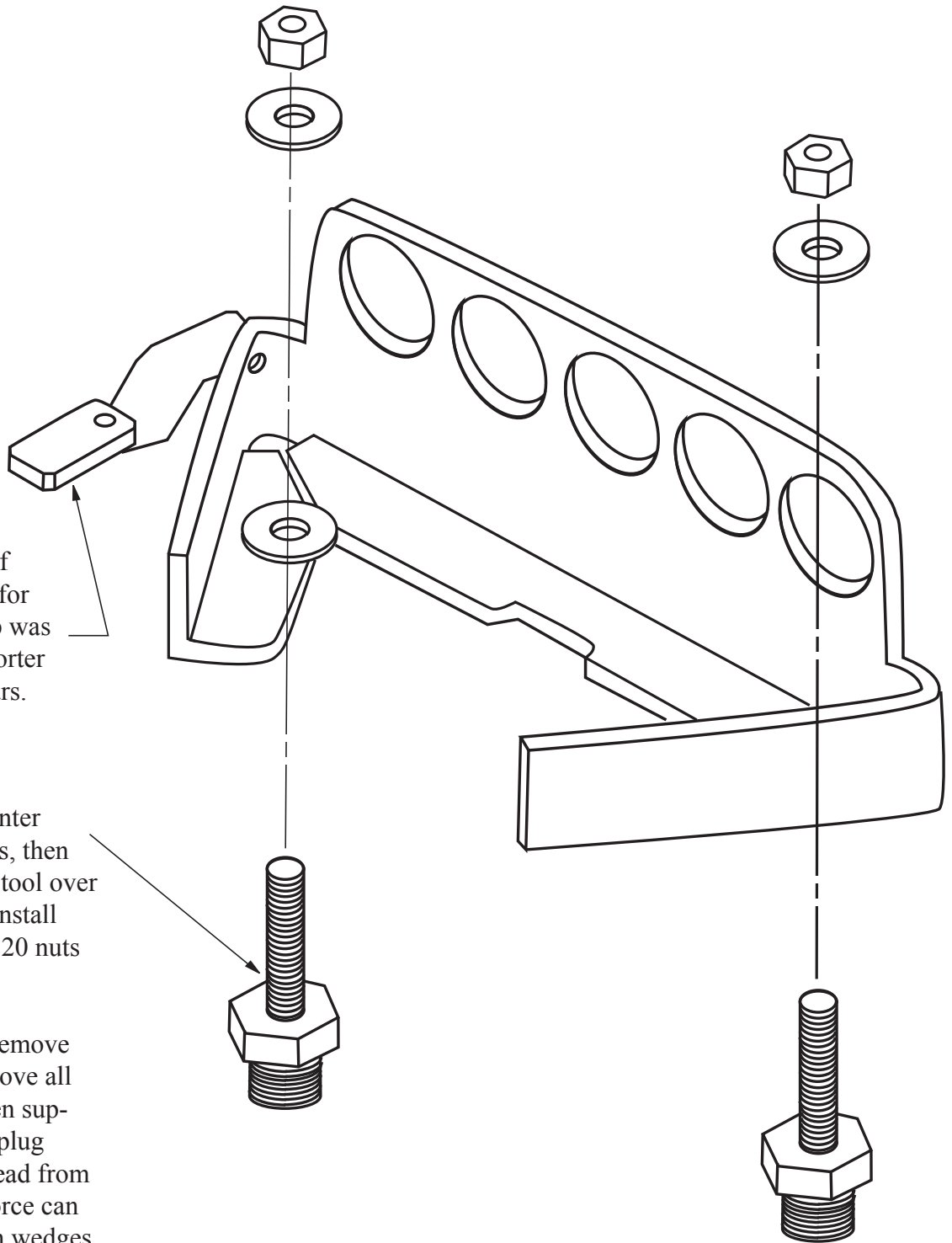

Shim used only if 1/4" longer stud for distributor clamp was replaced with shorter stud over the years.

Thread fully into center two spark plug holes, then install lifter / puller tool over supplied studs and install washers and 7/16 - 20 nuts installed.

Then using tool to remove stubborn head, remove all head nuts and tighten supplied nuts on spark plug studs to help jack head from block. Additional force can then be applied with wedges and lifting holes.